



## SF COOLING FANS

### Fan Components and Material Properties

The propeller is manufactured from electrostatic powder coated sheet metal, protective wire and wire mesh electrostatic powder coated steel wire. The propeller is coupled directly to the motor. Protective and carrier wireframe produced in standard connection dimensions.

\* Square Plate and Flat Grill options are available. Please contact BVN representatives.

### Benefits

With its blower and suction types, the SF cooling fans are designed for high performance, low noise level and long-term maintenance-free operation in a variety of applications. Speed can be adjusted

with speed control devices. Propellers are manufactured in the most ideal angle according to their size and maximum performance is ensured.

### Speed Control

Optional control devices can be provided. 1~Phase products can be controlled with linear voltage regulator (see BSC accessory). \* In line with the demand, three-phase models can be produced in accordance with the inverter.

### Usage Areas

Refrigeration machines, laboratories, residences, air-conditioning outdoor units, hot and cold air appliances and industrial chillers etc. used in places.

### Technical Drawing and Tables

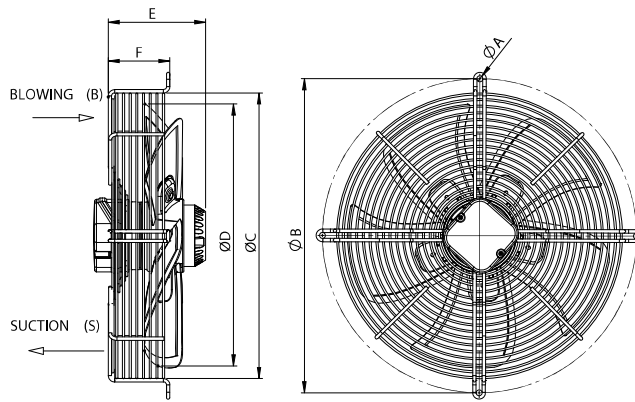

TYPE	A	B	C	D	E	F
SF 250	6,5	321	280	250	115	75
SF 300	6,5	360	329	300	115	61
SF 350	6,5	422	374	345	148	88
SF 400	9	470	422	396	146	93
SF 450	9	522	472	444	160	93

Dimensions are in (mm)

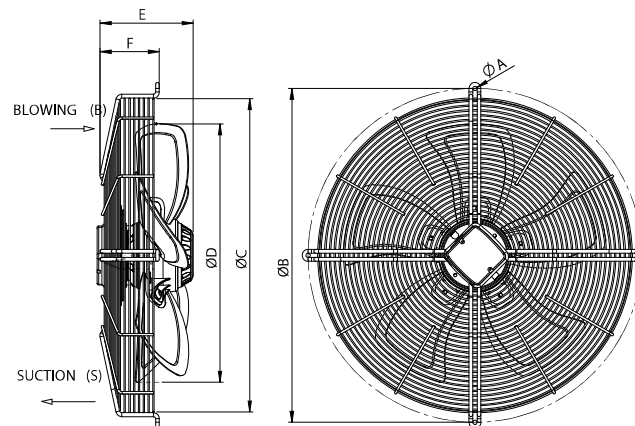

TYPE	A	B	C	D	E	F
SF 500	9	565	520	500	170	97
SF 560	9	700	654	552	198	124
SF 630	9	750	700	623	198	142

Dimensions are in (mm)

TYPE	VOLTAGE	FREQUENCY	POWER	CURRENT	CAPACITOR	SPEED	AIR FLOW	SOUND PRESSURE	INSULATION CLASS	PROTECTION CLASS	WEIGHT
	V	Hz	W	(A)	(µF)	r.p.m	m³/h	dB(A)	Ins.cl.	IP	kg
SF-4M 250 B	230	50/60	50/60	0,22/0,26	2	1400/1670	1000/1190	44	F	54	2,5
SF-4M 300 B	230	50/60	72/87	0,32/0,38	2,5	1300/1450	1700/1900	50	F	54	4
SFX-4M 300 B	230	50/60	100/120	0,5/0,54	3,5	1450/1710	1900/2240	50	F	54	4
SF-4M 350 B	230	50/60	165/195	0,75/0,85	4	1380/1545	3300/3700	55	F	54	4,7
SF-4M 400 B	230	50/60	160/220	0,75/1,1	5	1400/1650	4000/4700	58	F	54	6,1
SF-4M 450 B	230	50/60	245/355	1,2/1,6	7	1400/1600	5700/6500	63	F	54	6,9
SFX-6M 450 B	230	50/60	165/220	0,75/0,95	4	910/1025	4575/5225	55	F	54	6,9
SF-4M 500 B	230	50/60	450/600	1,98/2,65	10	1300/1450	6900/7700	65	F	55	9,5
SFX-4M 500 B	230	50	750	3,28	16	1260	9250	66	F	55	10,5
SFX-6M 500 B	230	50/60	220/275	0,99/1,2	6,3	850	6240	58	F	55	10,5
SFX-4M 560 B	230	50	1000	4,8	12,5	1250	11000	81	F	55	15
SFX-6M 560 B	230	50	450	2	10	875	8000	62	F	55	15
SFX-6M 630 B	230	50/60	630/750	2,9	12,5	850	11000	65	F	55	18
SFX-4T 300 B	Y380/Δ220	50/60	90/108	0,29/0,52	-	1450/1710	1900/2240	50	F	54	4
SF-4T 350 B	Y380/Δ220	50/60	160/170	0,33/0,58	-	1380/1545	3300/3700	55	F	54	4,7
SF-4T 400 B	Y380/Δ220	50/60	140/190	0,47/0,8	-	1400/1650	4000/4700	58	F	54	6,1
SF-4T 450 B	Y380/Δ220	50/60	200/285	0,5/0,55	-	1400/1600	5700/6500	63	F	54	6,9
SF-4T 500 B	380 Δ / Y	50	425/250	0,87/0,45	-	1300/1000	6900/5300	65	F	55	9,5
SFX-4T 500 B	380 Δ / Y	50	800/550	1,6/0,95	-	1260/1000	9250/7340	66	F	55	10,5
SFX-8T 500 B	380 Δ / Y	50/60	150/85	0,40/0,15	-	650/550	4770/4040	52	F	55	10,5
SFX-4T 560 B	380 Δ / Y	50	1200/800	2,6/1,5	-	1325/1050	12000/9500	68	F	55	15
SFX-6T 560 B	380 Δ / Y	50	500/300	1/0,5	-	875/650	8000/5950	62	F	55	15
SFX-6T 630 B	380 Δ / Y	50/60	600/400/720/475	1,25/0,70/1,37/0,73	-	850/650/900/695	11000/8400/11650/9000	65/67	F	54	18
SF-4M 250 S	230	50/60	50/60	0,22/0,26	2	1400/1670	1000/1190	44	F	54	2,5
SF-4M 300 S	230	50/60	72/87	0,32/0,38	2,5	1300/1450	1700/1900	50	F	54	4
SFX-4M 300 S	230	50/60	100/120	0,5/0,54	3,5	1450/1710	1900/2240	50	F	54	4
SF-4M 350 S	230	50/60	165/195	0,75/0,85	4	1380/1545	3300/3700	55	F	54	4,7
SF-4M 400 S	230	50/60	160/220	0,75/1,1	5	1400/1650	4000/4700	58	F	54	6,1
SF-4M 450 S	230	50/60	245/355	1,2/1,6	7	1400/1600	5700/6500	63	F	54	6,9
SFX-6M 450 S	230	50/60	165/220	0,75/0,95	4	910/1025	4575/5225	55	F	54	6,9
SF-4M 500 S	230	50/60	450/600	1,98/2,65	10	1300/1450	6900/7700	65	F	55	9,5
SFX-4M 500 S	230	50	750	3,28	16	1260	9250	66	F	55	10,5
SFX-6M 500 S	230	50/60	220/275	0,99/1,2	6,3	850	6240	58	F	55	10,5
SFX-4M 560 S	230	50	1000	4,8	12,5	1250	11000	81	F	55	15
SFX-6M 560 S	230	50	450	2	10	875	8000	62	F	55	15
SFX-6M 630 S	230	50/60	630/750	2,9	12,5	850	11000	65	F	55	18
SFX-4T 300 S	Y380/Δ220	50/60	90/108	0,29/0,52	-	1450/1710	1900/2240	50	F	54	4
SF-4T 350 S	Y380/Δ220	50/60	160/170	0,33/0,58	-	1380/1545	3300/3700	55	F	54	4,7
SF-4T 400 S	Y380/Δ220	50/60	140/190	0,47/0,8	-	1400/1650	4000/4700	58	F	54	6,1
SF-4T 450 S	Y380/Δ220	50/60	200/285	0,5/0,55	-	1400/1600	5700/6500	63	F	54	6,9
SF-4T 500 S	380 Δ / Y	50	425/250	0,87/0,45	-	1300/1000	6900/5300	65	F	55	9,5
SFX-4T 500 S	380 Δ / Y	50	800/550	1,6/0,95	-	1260/1000	9250/7340	66	F	55	10,5
SFX-8T 500 S	380 Δ / Y	50/60	150/85	0,40/0,15	-	650/550	4770/4040	52	F	55	10,5
SFX-4T 560 S	380 Δ / Y	50	1200/800	2,6/1,5	-	1325/1050	12000/9500	68	F	55	15
SFX-6T 560 S	380 Δ / Y	50	500/300	1/0,5	-	875/650	8000/5950	62	F	55	15
SFX-6T 630 S	380 Δ / Y	50/60	600/400/720/475	1,25/0,70/1,37/0,73	-	850/650/900/695	11000/8400/11650/9000	65/67	F	54	18

Sound Level Measured from 3m distance in room condition.

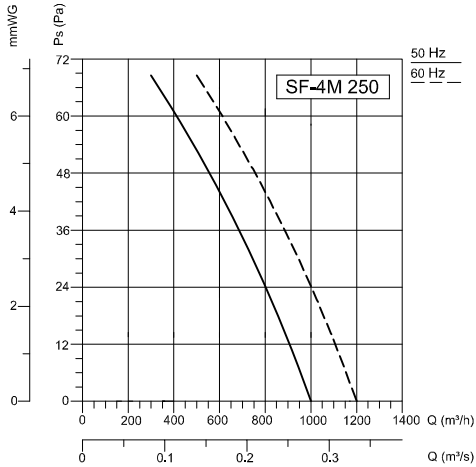

Frequency	Tot	63	125	250	500	1000	2000	4000	8000	Hz
$L_{WA}$ Inlet	51	22	40	46	44	45	42	23		dB(A)

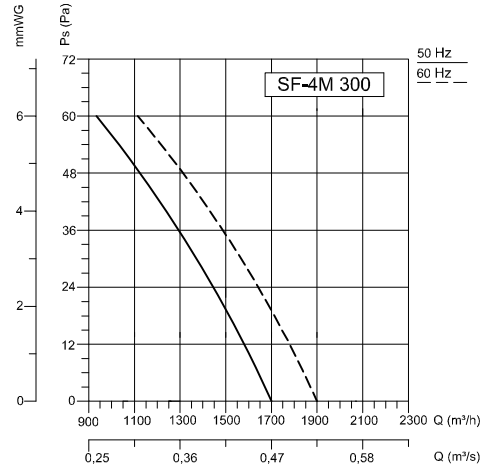

Frequency	Tot	63	125	250	500	1000	2000	4000	8000	Hz
$L_{WA}$ Inlet	51	22	40	46	44	45	42	23		dB(A)

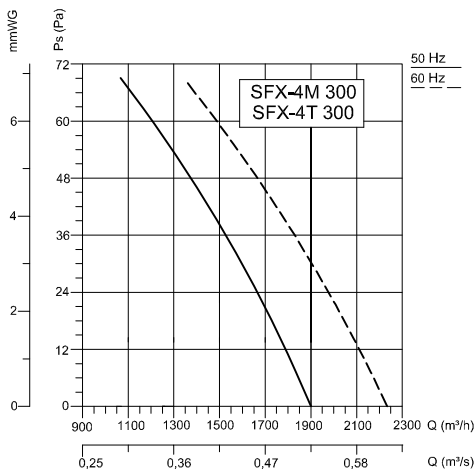

Frequency	Tot	63	125	250	500	1000	2000	4000	8000	Hz
$L_{WA}$ Inlet	58	30	48	53	51	52	49	32		dB(A)

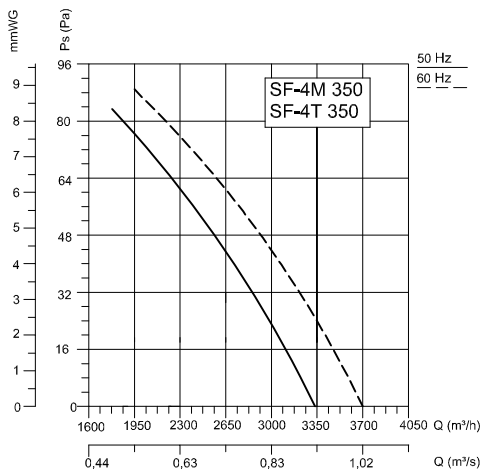

Frequency	Tot	63	125	250	500	1000	2000	4000	8000	Hz
$L_{WA}$ Inlet	62	43	52	53	55	57	55	54		dB(A)

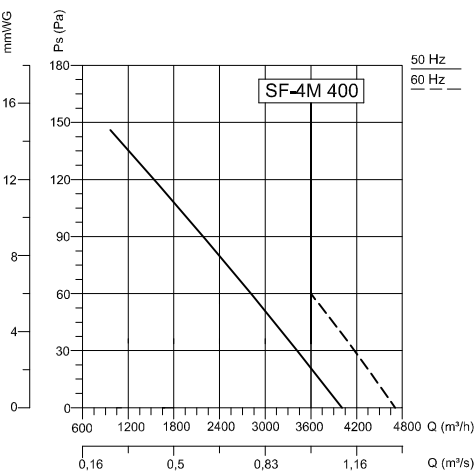

Frequency	Tot	63	125	250	500	1000	2000	4000	8000	Hz
$L_{WA}$ Inlet	65	56	53	59	57	59	59	47		dB(A)

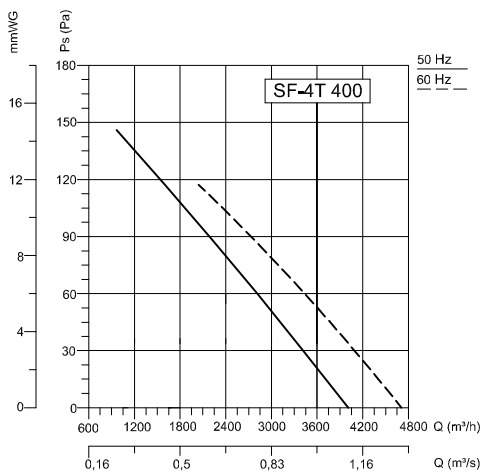

Frequency	Tot	63	125	250	500	1000	2000	4000	8000	Hz
$L_{WA}$ Inlet	65	56	53	59	57	59	59	47		dB(A)

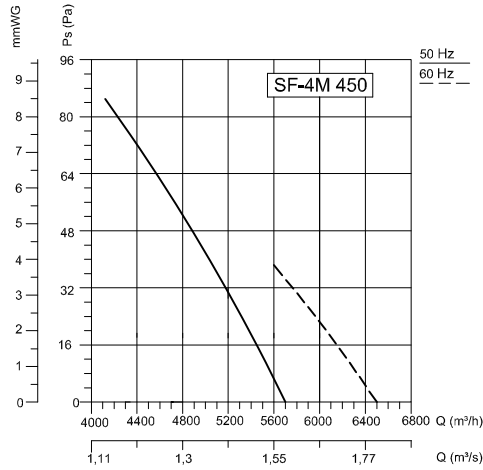

Frequency	Tot	63	125	250	500	1000	2000	4000	8000	Hz
$L_{WA}$ Inlet	70	51	60	62	65	65	53	51		dB(A)

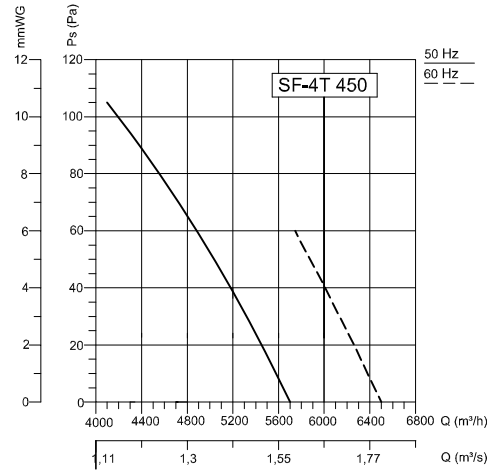

Frequency	Tot	63	125	250	500	1000	2000	4000	8000	Hz
$L_{WA}$ Inlet	70	51	60	62	65	65	53	51		dB(A)

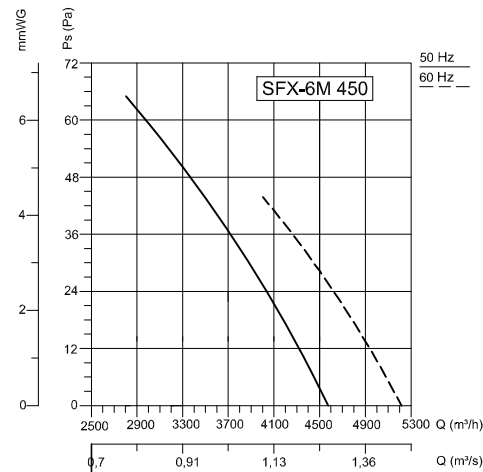

Frequency	Tot	63	125	250	500	1000	2000	4000	8000	Hz
$L_{WA}$ Inlet	62	43	52	53	55	57	55	54		dB(A)

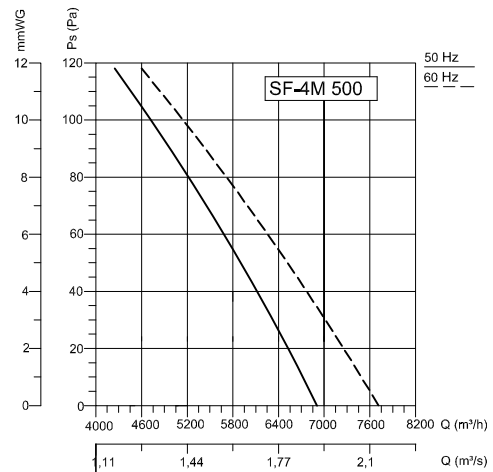

Frequency	Tot	63	125	250	500	1000	2000	4000	8000	Hz
$L_{WA}$ Inlet	72	53	61	63	66	67	65	53		dB(A)

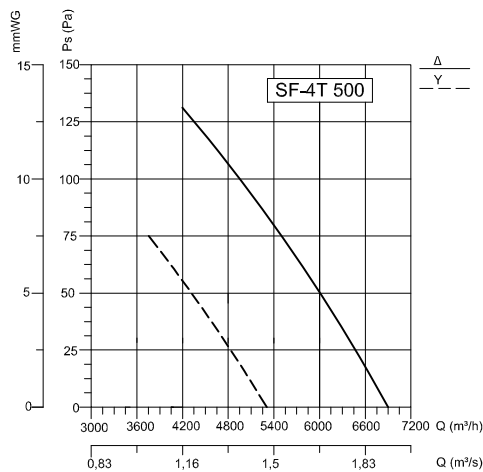

Frequency	Tot	63	125	250	500	1000	2000	4000	8000	Hz
$L_{WA}$ Inlet	72	53	61	63	66	67	65	53		dB(A)

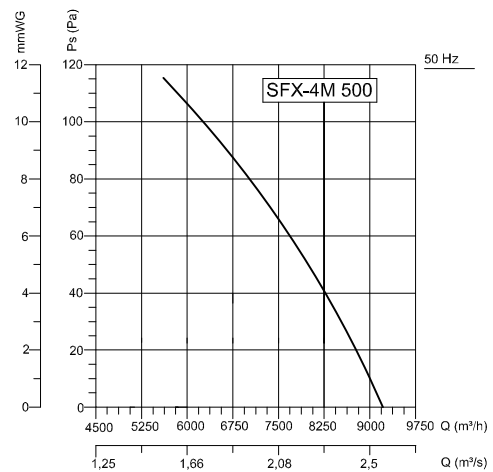

Frequency	Tot	63	125	250	500	1000	2000	4000	8000	Hz
$L_{WA}$ Inlet	73	54	62	64	67	68	66	54		dB(A)

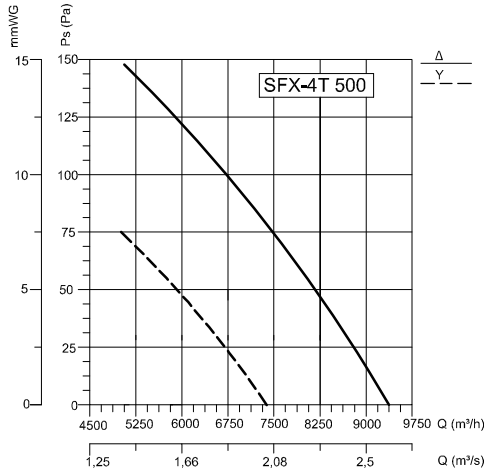

Frequency	Tot	63	125	250	500	1000	2000	4000	8000	Hz
$L_{WA}$ Inlet	73	54	62	64	67	68	66	54		dB(A)

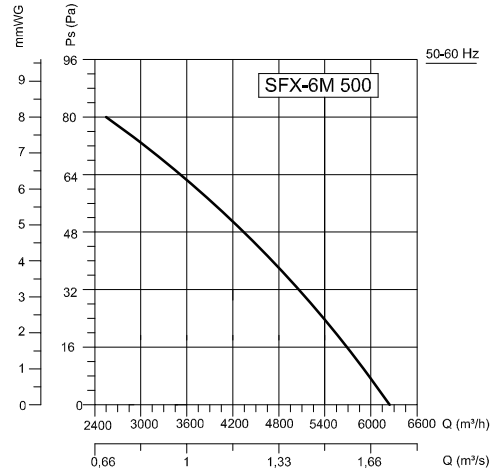

Frequency	Tot	63	125	250	500	1000	2000	4000	8000	Hz
$L_{WA}$ Inlet	65	56	53	59	57	59	59	59	47	dB(A)

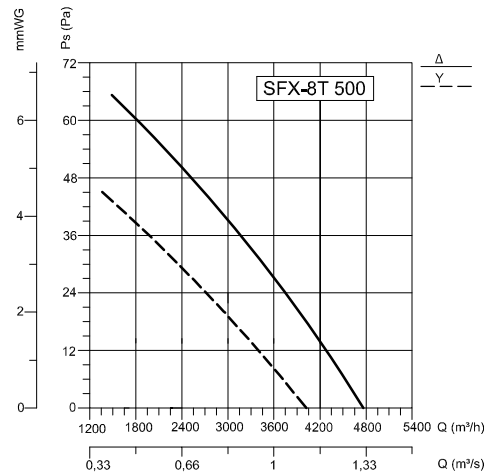

Frequency	Tot	63	125	250	500	1000	2000	4000	8000	Hz
$L_{WA}$ Inlet	59	30	48	54	52	53	50	31		dB(A)

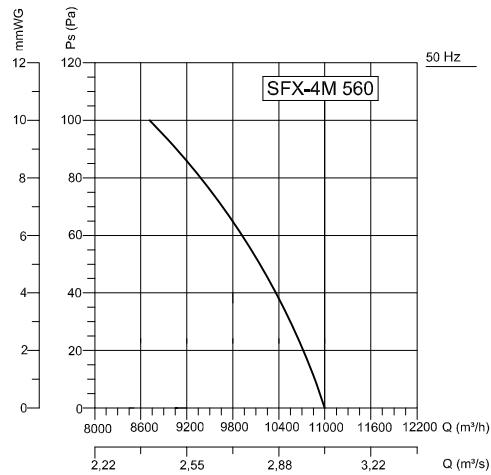

Frequency	Tot	63	125	250	500	1000	2000	4000	8000	Hz
$L_{WA}$ Inlet	75	59	65	68	70	69	65	56		dB(A)

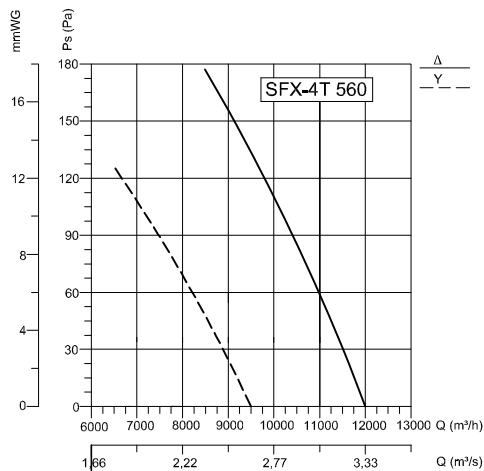

Frequency	Tot	63	125	250	500	1000	2000	4000	8000	Hz
$L_{WA}$ Inlet	75	59	65	68	70	69	65	56		dB(A)

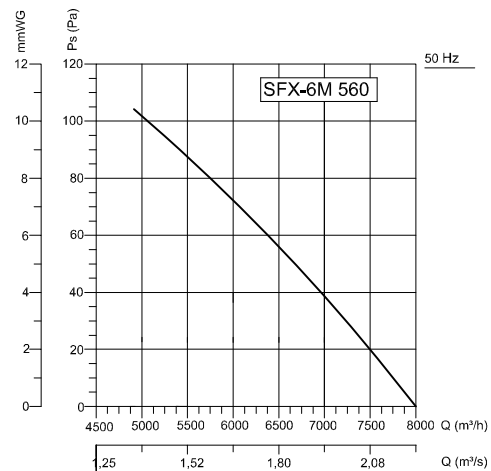

Frequency	Tot	63	125	250	500	1000	2000	4000	8000	Hz
$L_{WA}$ Inlet	69	53	59	62	64	63	59	50		dB(A)